



[CLICK for More Info Online](#)

## Weld-In Tubular Subframe Connectors with Bolt-In Connector Center Support

### Hardtop



Our weld-in subframe connectors are available for both hardtop and convertible models. Hardtop connectors are constructed from 2 x 2 x .083" wall boxed tubing with a single mandrel bend to tightly follow the contour of the undercarriage and to better visually blend with the factory subframes. 1-5/8 x .134" wall round tubing is used for the convertible connectors to achieve maximum ground clearance below the lower reinforcement pans. The ends of each connector are completely sealed by the 7 gauge formed sheet metal mounts. Both front and rear mounts extend to the height of their respective attachment points to place the securing weld at the strongest point of the factory subframe. Mounting holes are predrilled for simple installation of our available connector supports.

#### Features

- Weld-in installation
- Completely sealed construction
- Tightly follows undercarriage sheet metal
- Pre-drilled for add-on connector support

#### Hardtop (details)

- 2 x 2 x .083" wall boxed tubing

#### Convertible (details)

- 1-5/8 x .134" wall round tubing

# Weld-In Tubular Subframe Connectors

## Convertible



## Applications - Subframe Connectors

Make	Model	Year	Body Style	Part Number
Ford	Mustang	1964-1970	Convertible	TCP SUBFC-02
			Coupe	TCP SUBFC-01
			Fastback	TCP SUBFC-01
Mercury	Cougar	1967-1970	Convertible	TCP SUBFC-02
			Hardtop	TCP SUBFC-01

## System Installation

The weld-in subframe connectors serve as the base for our bolt-in connector center supports. Installation of the connector support requires a 3/8" bit to drill through the mounting locations using our subframe connectors or connector support as a drill jig. A supplied shim set is used to achieve a perfect fit every time.

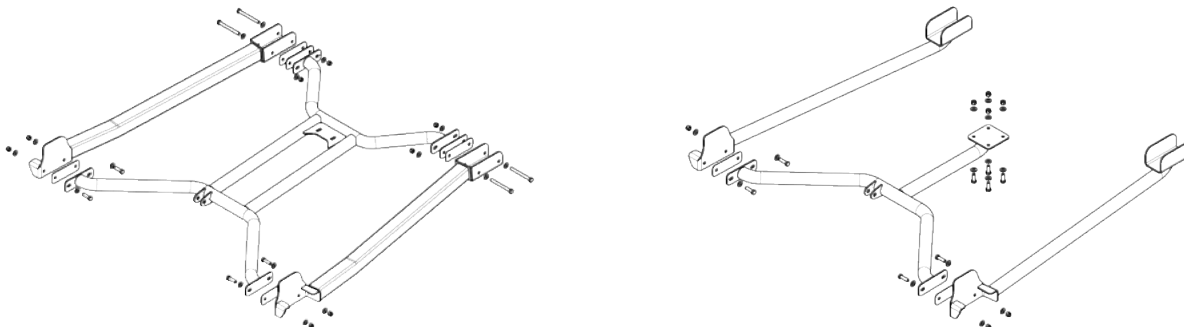

## Hardtop



Our bolt-in connector supports are constructed from 1-5/8 x .134" wall round tubing and secured to our weld-in subframe connectors with supplied grade 8 hardware. Diagonal bracing across the undercarriage creates a single reinforcement structure that includes the factory subframe and our weld-in subframe connectors. The 7 gauge mounting tabs are slotted to allow for chassis variances. Hardtop versions are equipped with a driveshaft-loop mounting plate that also reinforces the welded joints. For added exhaust clearance the assembly is angled downward, sitting 1-1/2" below the forward factory subframe at it's lowest point. Connector supports are powder-coated black and ship with required mounting hardware.

## Driveshaft Safety Loop

Our bolt-on driveshaft safety loop features a 5-1/2" ID x 2" wide x 1/4" thick tubing loop. Both the mounting tab and bracket are 1/4" thick mild steel and are secured with grade 8 fasteners. Slotted holes at each of the attachment points allow the loop position to be adjusted for various transmission lengths and driveshaft angles (1/2" vertical, 3/8" horizontal, 3-5/16" fore/aft). Components are powder-coated and zinc plated for corrosion resistance. Installation of our connector support for hardtops is required.



### Features

- Bolt-in installation
- 1-5/8 x .134" wall round tubing
- Completely sealed construction
- Allows room for dual exhaust

### Hardtop (details)

- 4-point mounting
- Integrated driveshaft loop mount
- Optional 5-1/2" driveshaft loop

### Convertible (details)

- 3-point mounting
- Ties into lower reinforcement pans

Part Number	Description
TCP DSL-01	Driveshaft Safety Loop

# Bolt-In Connector Center Supports

## Convertible



## Applications - Connector Supports

Make	Model	Year	Body Style	Part Number
Ford	Mustang	1964-1970	Convertible	TCP SUBCS-03
			Coupe	TCP SUBCS-01
			Fastback	TCP SUBCS-01
Mercury	Cougar	1967-1970	Convertible	TCP SUBCS-03
			Hardtop	TCP SUBCS-01

## Packages

Part Number	Description
TCP PKG-SFC-51	Hardtop Connector System

Includes weld-in subframe connectors, bolt-in 4-point connector support, and driveshaft safety loop



Part Number	Description
TCP PKG-SFC-52	Convertible Connector System

Includes weld-in subframe connectors, and bolt-in 3-point connector support



All prices subject to change. Current pricing available at [www.cachassisworks.com](http://www.cachassisworks.com).



Total Control Products  
8661 Younger Creek Drive - Sacramento, CA 95828  
A Chris Alston's Chassisworks, Inc. Brand

Order: 800-722-2269  
Tech: 916-388-0288  
Fax: 916-388-0295

[tcpsales@cachassisworks.com](mailto:tcpsales@cachassisworks.com)  
[tcptech@cachassisworks.com](mailto:tcptech@cachassisworks.com)  
[www.totalcontrolproducts.com](http://www.totalcontrolproducts.com)