

READ ALL INSTRUCTIONS COMPLETELY AND THOROUGHLY UNDERSTAND THEM BEFORE DOING ANYTHING.
CALL TOTAL CONTROL PRODUCTS TECH SUPPORT (916) 388-0288 IF YOU NEED ASSISTANCE.

INSTALLATION GUIDE



TCP COLM-05 For 1960 – 1965 Falcon/Comet with non-collapsible OEM steering shaft



Description: Lower column floor support bracket with column clamp and mounting hardware

Applications: Fits '60-'65 Falcon/Comet with 2-1/4" columns

PARTS LIST

COLM-05 - Lower Column Support 60-65 Falcon/Comet

Qty	Part Number	Description
1	7900-055	Column clamp 2-1/4" OD column
1	7900-155	Lower column support plate 60-65 Falcon
1	7900-169	Column firewall seal 60-65 Falcon
1	7918-008	Hardware kit

7918-008 - Hardware Kit

Qty	Part Number	Description
6	3101-019-32C	Locknut 10-32 nylon insert
6	3104-019F0.75S	Button head 10-32 x 3/4" cap screw
2	3106-38FD0.75B	Set screw 3/8-24 x .75" long
6	3157-019S-S	Washer #10 stainless steel

INSTRUCTIONS

NOTE: A 1965 Mustang was used for the following images and show differences from the Falcon and Comet platforms. The installation procedure is identical.

1. Remove the OEM lower column plate and firewall seal.
2. Place the column support bracket against the inside of the firewall at the factory steering column hole.
3. Verify that the bolt pattern matches the existing holes.



4. If the support bracket pattern matches factory holes, remove the bracket and use a 13/64" bit to open up the holes.
5. If support bracket pattern does not match the factory holes, new holes will have to be drilled through the firewall to match the support bracket.
6. Mark the hole location with a center punch or begin drilling hole with bracket in place.
7. We suggest starting the holes then removing the bracket to reduce the chance of damaging the finish of the bracket.



8. Begin screwing the set screws into the support bracket. If the set screws do not thread in easily chase the threads in the bracket using a 3/8-24 tap. Do not thread past the inside edge of the support bracket.

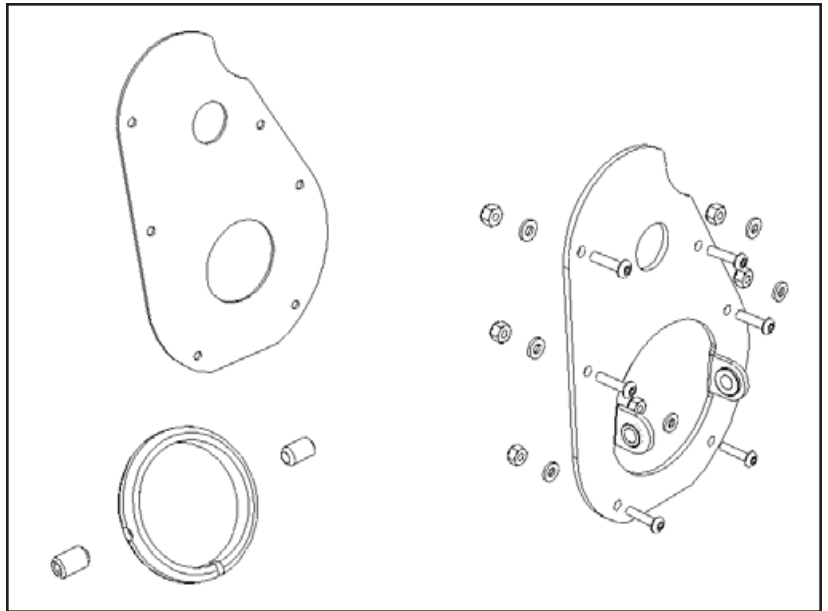

9. Place the firewal seal as shown and insert the 10-32 x 3/4" button head cap screws through the bracket on the seal.



10. The support bracket and column seal can be mounted to the firewall. Thread the locknuts onto the bolts from the engine compartment side and tighten.

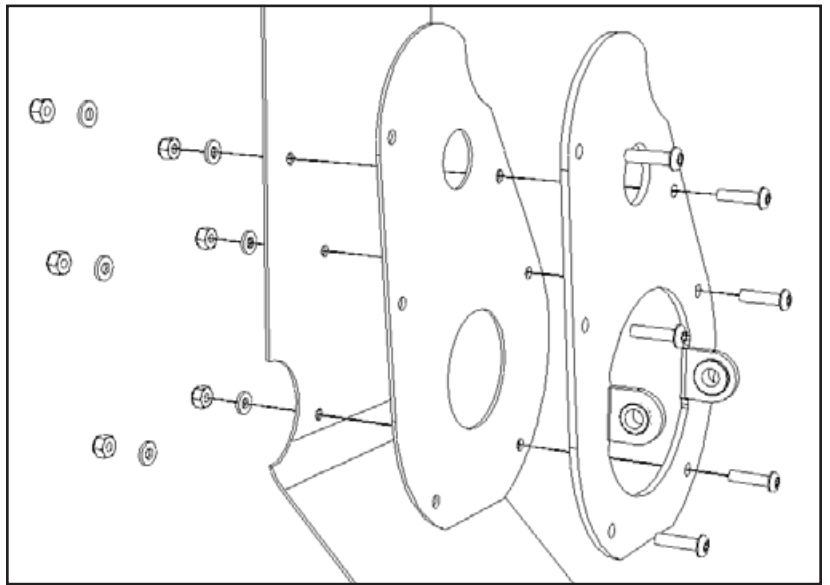
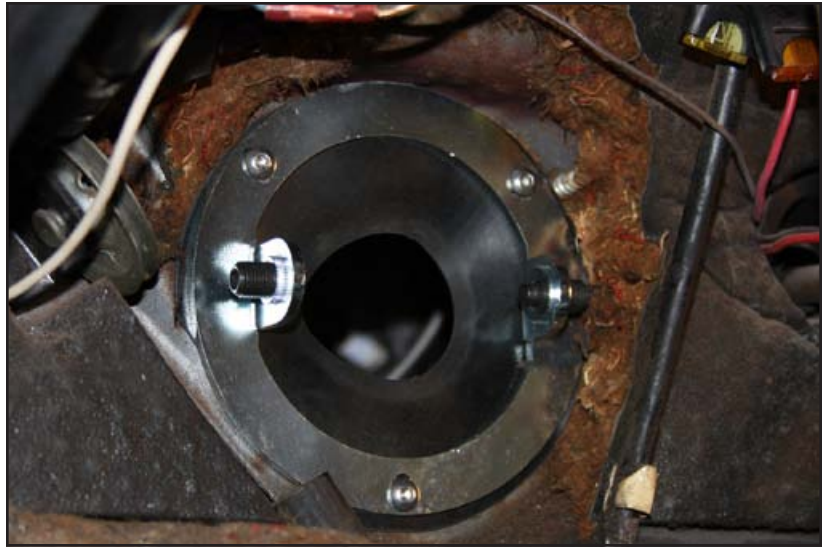

11. The column clamp will already be on steering column as instructed in the 7903-COLM-02 installation guide.



12. Insert completed steering column assembly through the firewall seal.

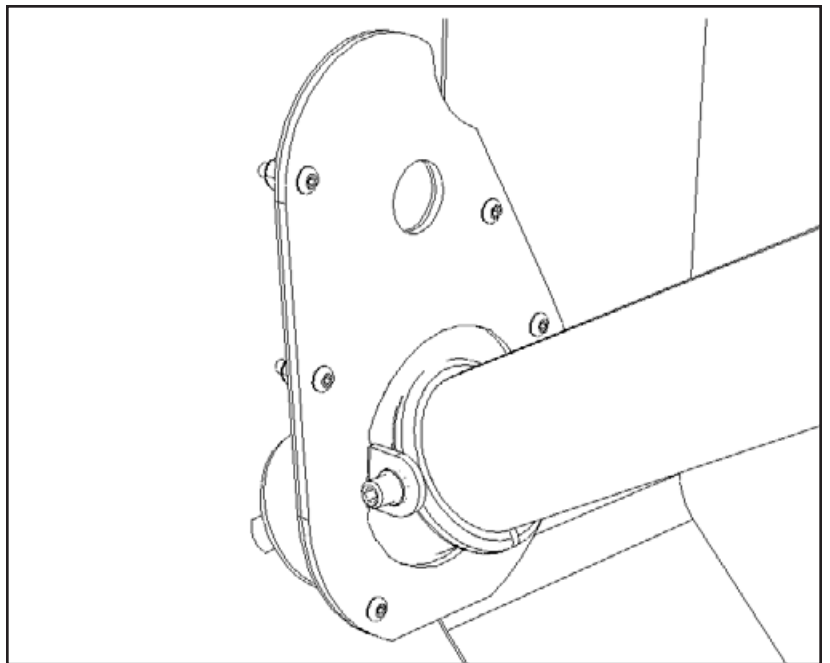

13. Seal will stretch to allow column to pass through.
14. Position column at original height.
15. Secure column using upper dash bracket.



16. Column clamp can now be slid into correct position to line up with set screws.



17. Continue tightening set screws until column is held securely.



18. The steering wheel can now be placed on the column. Do not fully tighten it until the rack and pinion has been centered, this is detailed in instruction sheet 7903-RCKP-XX.



NOTES:

WARRANTY NOTICE:

There are NO WARRANTIES, either expressed or implied. Neither the seller nor manufacturer will be liable for any loss, damage or injury, direct or indirect, arising from the use or inability to determine the appropriate use of any products. Before any attempt at installation, all drawings and/or instruction sheets should be completely reviewed to determine the suitability of the product for its intended use. In this connection, the user assumes all responsibility and risk. We reserve the right to change specification without notice. Further, Chris Alston's Chassisworks, Inc., makes **NO GUARANTEE** in reference to any specific class legality of any component. **ALL PRODUCTS ARE INTENDED FOR RACING AND OFF-ROAD USE AND MAY NOT BE LEGALLY USED ON THE HIGHWAY.** The products offered for sale are true race-car components and, in all cases, require some fabrication skill. **NO PRODUCT OR SERVICE IS DESIGNED OR INTENDED TO PREVENT INJURY OR DEATH.**

Total Control Products
A Chris Alston's Chassisworks, Inc. Brand
8661 Younger Creek Drive
Sacramento, CA 95828
Phone: 916-388-0288
Technical Support: tcptech@cachassisworks.com

