

WARRANTY NOTICE:

There are **NO WARRANTIES**, either expressed or implied. Neither the seller nor manufacturer will be liable for any loss, damage or injury, direct or indirect, arising from the use or inability to determine the appropriate use of any product. Before any attempt at installation, all drawings and/or instruction sheets should be completely reviewed to determine the suitability of the product for its intended use. In this connection, the user assumes all responsibility and risk. We reserve the right to change specification without notice. Further, Chris Alston's Chassisworks, Inc., makes **NO GUARANTEE** in reference to any specific class legality of any component. **ALL PRODUCTS ARE INTENDED FOR RACING AND OFF-ROAD USE AND MAY NOT BE LEGALLY USED ON THE HIGHWAY.** The products offered for sale are true race-car components and, in all cases, require some fabrication skill. **NO PRODUCT OR SERVICE IS DESIGNED OR INTENDED TO PREVENT INJURY OR DEATH.**



Total Control Products
A Chris Alston's Chassisworks, Inc. Brand
8661 Younger Creek Drive
Sacramento, CA 95828
Phone: 916-388-0288
Technical Support: tcptech@cachassisworks.com

7903-EE-03

REV 01/18/05

INSTALLATION GUIDE



Rack and Pinion Mount Spacers

For 1960 – 1966 Fords
with OEM shim method camber adjustment
(For use with TCP Rack-&-Pinion)

P/N: TCP EE-03

DESCRIPTION:

ECCENTRIC ELIMINATOR SPACER PLATES FOR LOWER CONTROL ARMS ONLY; .50 ID x 1.25 OD x .25 THICK

APPLICATIONS:

FITS '60-65 FALCON/COMET, '64-66 MUSTANGS; AND TCP LCA-01 LOWER CONTROL ARMS

PARTS LIST

Part Number	Description	Qty
7900-078	Spacer, .50 ID x 1.25 OD x .25 Thick	2

Orientation of rack and pinion mounting bracket will differ by application.

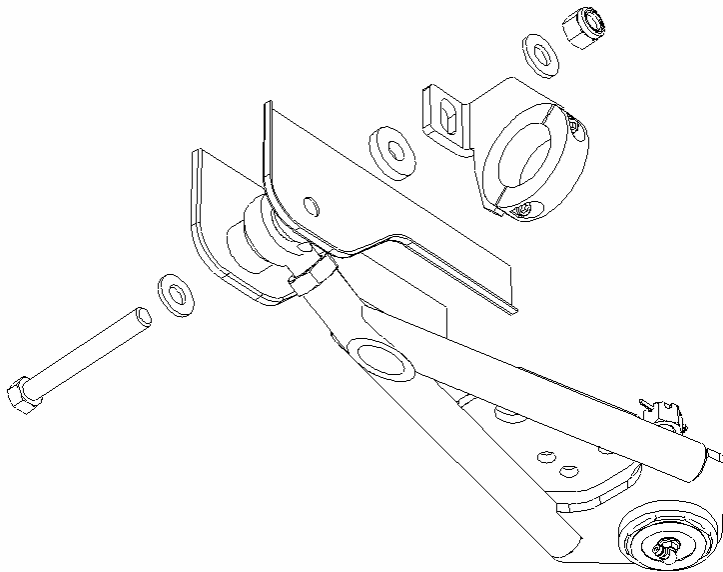

Additional hardware shown is included with the TCP Rack-&-Pinion and TCP Lower Control Arms.

INFORMATION

- Our Eccentric Eliminator Spacer is placed between the factory lower control arm mount and the rack-&-pinion mounting bracket on vehicles with non-adjustable lower control arm mounting position.
- TCP adjustable upper control arms or adjustment shims will be needed to make precise alignment settings.
- Torque 1/2" lower control arm bolts to 45 lb-ft.