

READ ALL INSTRUCTIONS COMPLETELY AND THOROUGHLY UNDERSTAND THEM BEFORE DOING ANYTHING.
CALL TOTAL CONTROL PRODUCTS TECH SUPPORT (916) 388-0288 IF YOU NEED ASSISTANCE.

INSTALLATION GUIDE



TCP PBS-FD-02

Pump Bracket Set Ford 02

Ford Small Block (Tall Deck) 351 Windsor, 351 Cleveland & 400M



DESCRIPTION:

Pump Bracket Set Ford 02 includes billet aluminum bracket; spacer set; and hardware; attaches power steering pump to driver side cylinder head

APPLICATIONS:

Fits Ford small block (tall deck) 351 Windsor, 351 Cleveland & 400M engines

PARTS LIST

TCP PBS-FD-02 - Power Steering Pump Bracket Set - Small Block Ford (Tall Deck)

Qty	Part Number	Description
1	7900-149	Pump Bracket SB Ford 351W/351C/400 Tall Deck Block
1	7918-009	Hardware Bag for TCP PBS-FD-02
1	7918-012	Spacer Set Ford Power Steering Pump Bracket

7918-009 - Hardware Bag

Qty	Part Number	Description
2	3100-031C2.75Y	Bolt 5/16-18 x 2-3/4" Hex Head Cap Screw
2	3100-031C3.50Y	Bolt 5/16-18 x 3-1/2" Hex Head Cap Screw
2	3100-038C4.25Y	Bolt 3/8-16 x 4-1/4" Hex Head Cap Screw
1	3100-038C4.50Y	Bolt 3/8-16 x 4-1/2" Hex Head Cap Screw
2	3100-044C4.00Y	Bolt 7/16-14 x 4" Hex Head Cap Screw
1	3100-044C4.50Y	Bolt 7/16-14 x 4-1/2" Hex Head Cap Screw
1	3119-031-18C	Flange Nut 5/16-18
2	3120-031S-Y	Washer 5/16 Flat SAE .345 x .690 x .060 Thick
3	3120-038S-Y	Washer 3/8 Flat SAE .410 x .810 x .060 Thick
2	3120-044S-Y	Washer 7/16 Flat SAE .470 x .925 x .060 Thick

7918-012 - Hardware Bag, Spacer Set

6	3109-044S1-S	Aircraft Washer 7/16 Flat .453 x .750 x .032 Thick
6	3109-044S2-S	Aircraft Washer 7/16 Flat .453 x .750 x .063 Thick
3	7900-170-0370	Spacer .453 ID x .370 Long x .75 OD with .850 Shoulder
3	7900-170-2910	Spacer .453 ID x 2.910 Long x .75 OD with .850 Shoulder

INSTRUCTIONS

1. Bolt bracket to cylinder head using the supplied 3/8" or 7/16" hardware. If additional accessories are mounting to cylinder head, spacers will need to be shortened. Bolts do not need to be tightened at this time.



3/8-16 x 4-1/2" or
7/16-14 x 4-1/2"

3/8-16 x 4-1/4"
or 7/16-14 x 4"

NOTE: 7/16" washer is
not used in counterbore.

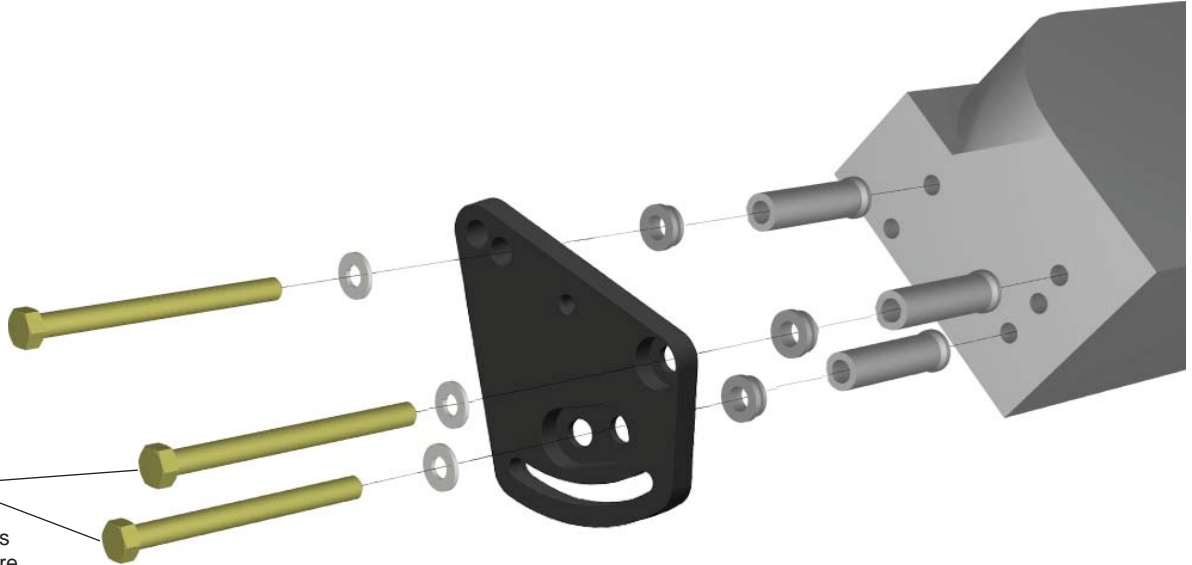

2. Attach pump to bracket using 5/16" hardware. Hardware can be inserted through pulley. See following page for pump specific hardware illustrations.



Pro Pump

Use 3-1/2" long 5/16" bolts at opposite mounting holes; red or yellow pair. Each hole pair changes the final angle of the pump slightly with the belt fully tensioned.

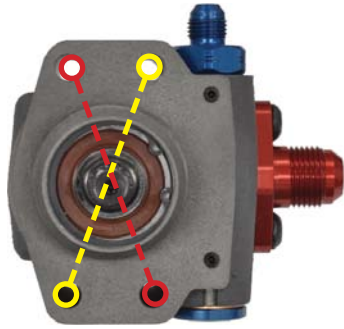

5/16-18 x 3-1/2"



5/16-18 x 3-1/2"

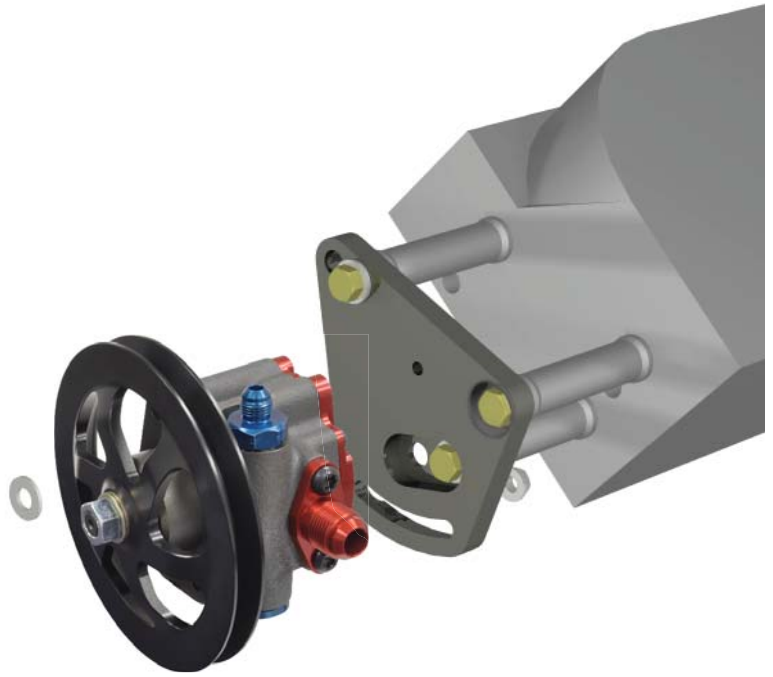

Street Pump

Use 2-3/4" long 5/16" bolts at top and bottom mounting holes.

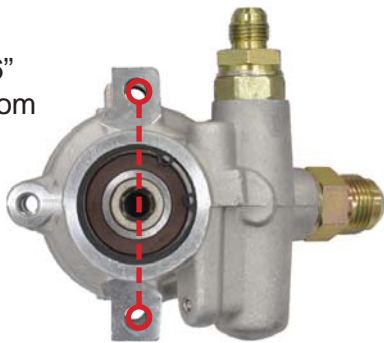

5/16-18 x 2-3/4"



5/16-18 x 2-3/4"

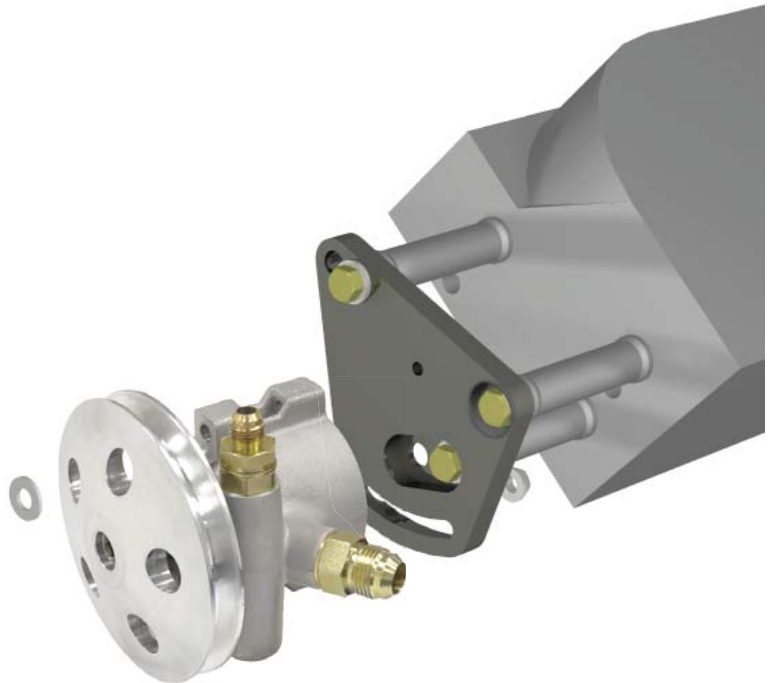

3. Use a straight edge along face of pulleys to measure correct amount to shim bracket for alignment.



4. Remove pump and loosen bracket bolts.
5. Add shims between aluminum spacers as required to align the pulley grooves.
6. Attach pump to bracket using 5/16" hardware to recheck alignment of pulleys. If alignment is correct, remove pump and tighten bracket bolts to 12-18 lb-ft.

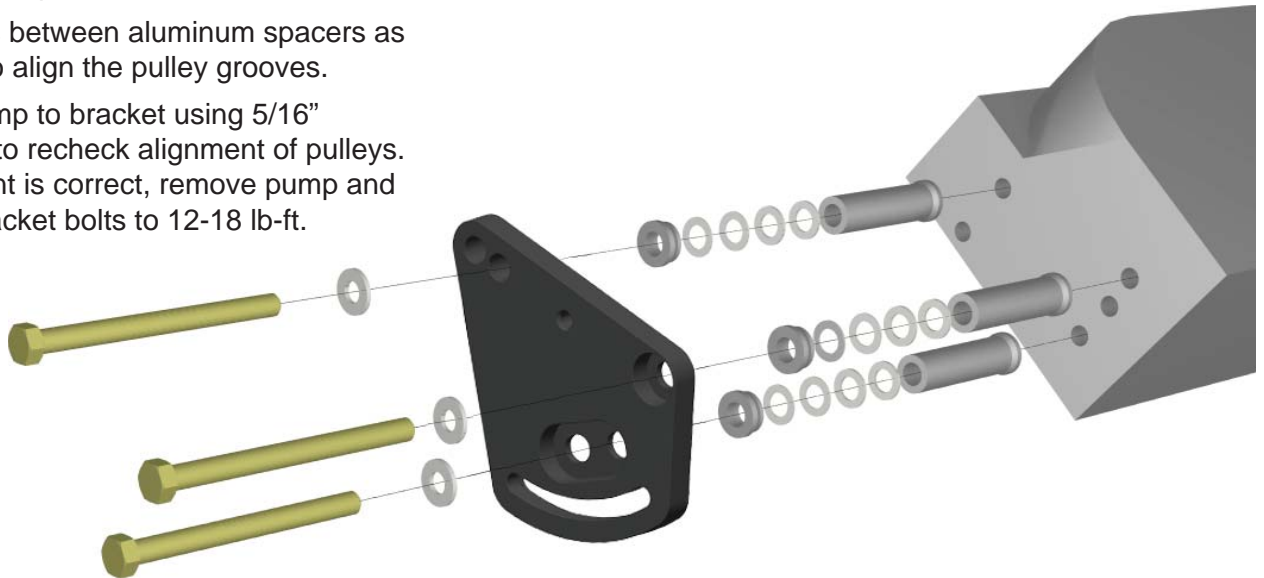

7. Attach pump to bracket using 5/16" hardware.
8. Upper bolt is the pivot bolt and should be installed 'finger-tight' while measuring belt length.
9. A rope can be used to establish a starting point for finding the correct length belt for use with you particular pulley combination.



10. Insert the flanged nut into the tensioning slot on the backside of the bracket. The flanged part of the nut must lie against the bracket.
11. The lower 5/16" bolt goes inserts through the pulley and lower pump mounting hole and into the flange nut.
12. Tighten both bolts to 12-18 ft-lb., while holding tension on the belt.
13. See Hose Kit instructions for hose assembly, routing and hook-up.



WARRANTY NOTICE:

There are NO WARRANTIES, either expressed or implied. Neither the seller nor manufacturer will be liable for any loss, damage or injury, direct or indirect, arising from the use or inability to determine the appropriate use of any products. Before any attempt at installation, all drawings and/or instruction sheets should be completely reviewed to determine the suitability of the product for its intended use. In this connection, the user assumes all responsibility and risk. We reserve the right to change specification without notice. Further, Chris Alston's Chassisworks, Inc., makes **NO GUARANTEE** in reference to any specific class legality of any component. **ALL PRODUCTS ARE INTENDED FOR RACING AND OFF-ROAD USE AND MAY NOT BE LEGALLY USED ON THE HIGHWAY.** The products offered for sale are true race-car components and, in all cases, require some fabrication skill. **NO PRODUCT OR SERVICE IS DESIGNED OR INTENDED TO PREVENT INJURY OR DEATH.**

Total Control Products
A Chris Alston's Chassisworks, Inc. Brand
8661 Younger Creek Drive
Sacramento, CA 95828
Phone: 916-388-0288
Technical Support: tcptech@cachassisworks.com

