

INSTALLATION GUIDE



Subframe Connectors 02 Convertible, Weld-In Installation

P/N: TCP SUBFC-02

DESCRIPTION:

WELD-IN SUBFRAME CONNECTORS; CONNECTS FRONT AND REAR FACTORY FRAME RAILS TO INCREASE CHASSIS RIDGIDITY

APPLICATIONS:

FITS COUGAR 67-70, MUSTANG 64-70

WARRANTY NOTICE:

There are **NO WARRANTIES**, either expressed or implied. Neither the seller nor manufacturer will be liable for any loss, damage or injury, direct or indirect, arising from the use or inability to determine the appropriate use of any product. Before any attempt at installation, all drawings and/or instruction sheets should be completely reviewed to determine the suitability of the product for its intended use. In this connection, the user assumes all responsibility and risk. We reserve the right to change specification without notice. Further, Chris Alston's Chassisworks, Inc., makes **NO GUARANTEE** in reference to any specific class legality of any component. **ALL PRODUCTS ARE INTENDED FOR RACING AND OFF-ROAD USE AND MAY NOT BE LEGALLY USED ON THE HIGHWAY.** The products offered for sale are true race-car components and, in all cases, require some fabrication skill. **NO PRODUCT OR SERVICE IS DESIGNED OR INTENDED TO PREVENT INJURY OR DEATH.**

Total Control Products
A Chris Alston's Chassisworks, Inc. Brand
8661 Younger Creek Drive
Sacramento, CA 95828
Phone: 916-388-0288
Technical Support: tcptech@cachassisworks.com



PARTS LIST

Item	Part Number	Description	Qty.
1	7908-065	Frame Connector Weldment Driver Side, Convertible	1
2	7908-066	Frame Connector Weldment Passenger Side, Convertible	1

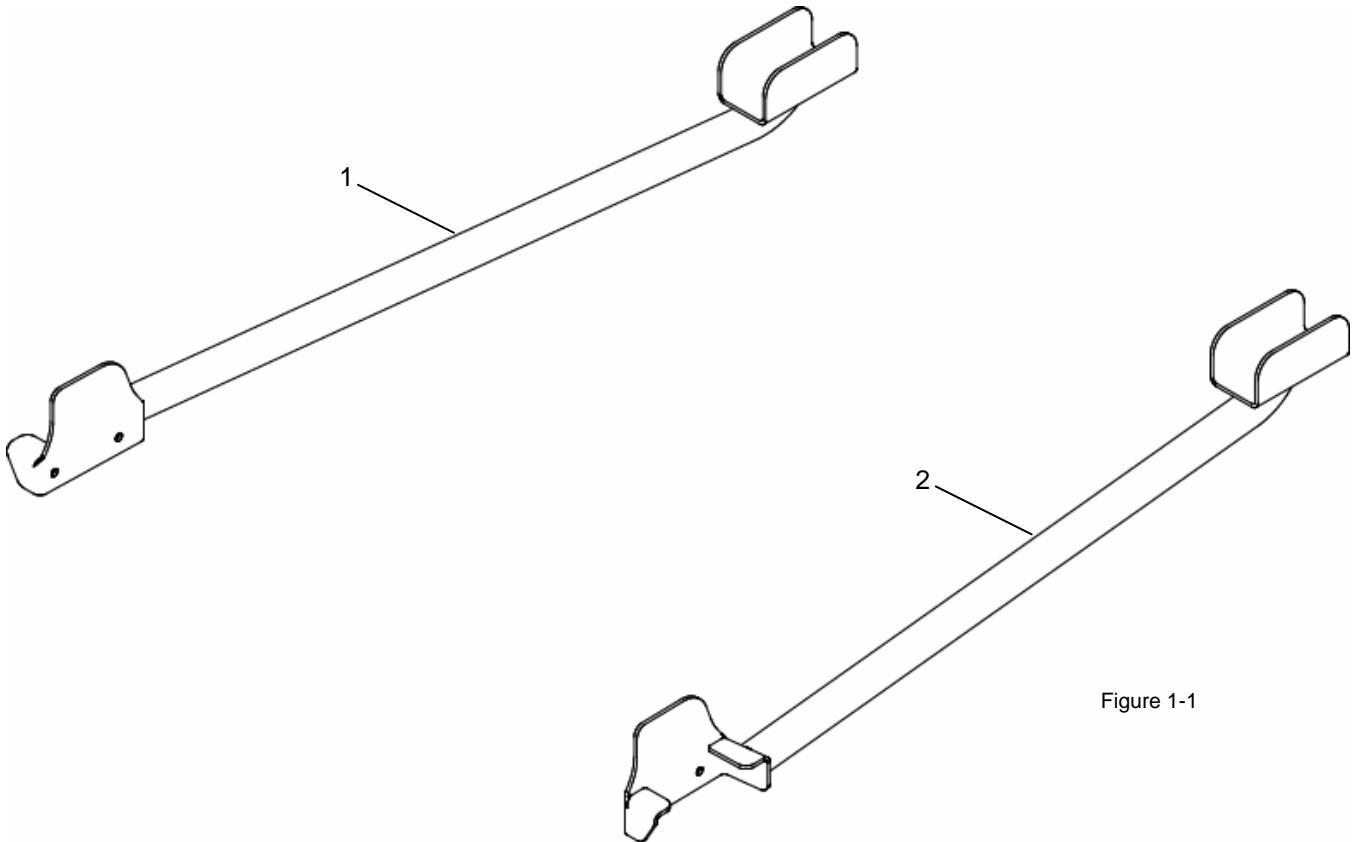

Figure 1-1

INSTRUCTIONS

Images may differ slightly from actual product received.

1. Remove carpet, insulation and wiring from areas of floorboard that will be affected by heat from welding. This is done to reduce the risk of damage and potential fire.
2. Temporarily relocate fuel and brake lines that are near the installation area (Figure 1-2).
 - a. Some installations may require lines to be rerouted, modified, or the subframe connectors to be notched.
 - b. Be sure there is adequate clearance between the fuel line and the welding area to prevent potential fire.



Figure 1-2

3. Place back edge of subframe connector 1" forward from center of leaf spring mounting bolt to see where the connector will be position (Figure 2-1).
4. Using a steel brush attachment and drill, remove powder coating from edges of subframe connector where welds will be made (Figure 2-2).
5. Remove any coating or grease that may be along the weld area of the factory frame rails using the steel brush attachment (Figures 2-3 & 2-4).
6. The front cup of the subframe connector should slip over the factory frame rail.
 - a. If there is jack damage to the frame rails, the metal will need to be straightened enough for the subframe connector to seat properly.
 - b. Some installations may require the emergency brake cable bracket to be modified.
 - i. Grind away the spot welds on the rear of the bracket.
 - ii. With a cut-off wheel, remove the section of the bracket that lies against the frame rail.
 - iii. Grind a notch in the bracket wide enough to slip the front cup of the subframe connector into.
 - iv. The front cup should seat on the frame rail without interference from the bracket.

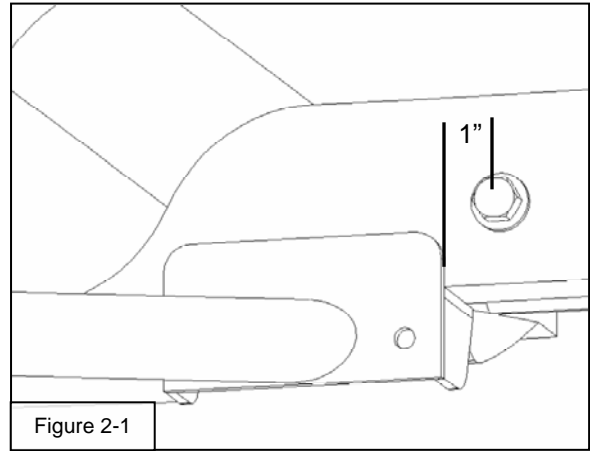

Figure 2-1



Figure 2-2



Figure 2-3



Figure 2-4



Figure 2-5



Figure 2-6

7. The rear cup seats on the bottom corner of the frame rail 1" forward of the leaf spring mounting point (Figures 2-1 & 2-6).
8. Hold subframe connector firmly in position so that plate is tight against frame rail and tack weld at each end (Figure 2-6).
9. Position the opposite subframe connector but do not tack weld at this time.
 - a. Measure diagonally from the forward cup of one connector to the rear cup of the opposite connector.
 - b. Measure diagonally in the opposite direction and compare the two dimensions. Shift loose connector forward or backward to bring the measurements within 1/8".
10. Once positioned correctly tack weld the second connector and verify dimensions again.
11. Weld a complete bead around all sides of the front and rear end cups (Figure 3-1).
 - a. Do not fill the holes pre-drilled into the subframe connector end cups. These holes are used when mounting the optional center support.
12. Paint the areas of exposed metal to protect against rust (Figure 3-2).
13. This completes the installation of your Subframe Connectors.

